



华芯科技有限公司

HUAXIN TECHNOLOGY CO., LTD

SPECIFICATION FOR LCD MODULE

Customer : _____

CustomerP/N _____

Model No. : ESHX035HHD8490ANT

Version : 1.0

Date : 2022-08-09

Final Approval by Customer

LCM Machinery OK <input type="checkbox"/>	Checked By	
LCM Display OK <input type="checkbox"/>	Checked By	
LCM NG <input type="checkbox"/> LCM OK <input type="checkbox"/>	Approved By	

Confirmed :

DESIGN	CHECK	APPROVAL

Table of Contents

Revision History	3
1 General Specifications	4
2 Pin Assignment	5
3 Absolute Maximum Ratings	6
4 Electrical Characteristics	6
5 INTERFACE TIMING	8
6 Optical Characteristics	10
7 Environmental / Reliability Test	16
8 Mechanical Drawing	17
9 Precautions For Use of LCD Modules	18



华芯科技
HUAXIN TECHNOLOGY

华芯科技有限公司

HUAXIN TECHNOLOGY CO., LTD

Revision History

Rev	Issued Date	Description	Page	Editor
1.0	Aug.09,2022	First release	All	

1 General Specifications

Feature		Specifications
Display Spec.	LCD type	3.54inch
	Resolution (H*V)	800*(RGB)*640
	Technology Type	a-Si TFT
	Pixel Configuration	R.G.B. Vertical Stripe
	Normally White	Normally Black
	Viewing Direction	ALL
Mechanical Characteristics	OutlineDimensions (W x H x T) (mm)	97.6*87.39*4.12
	Active Area(mm)	90*72
	With /Without Touch screen	Without
	Match Connector Type	0.5 pitch 40pin
	Backlight Type	LED
	Weight (g)	TBD
Electrical Characteristics	Interface	SPI+RGB
	Number of color	16.7M
	Driver IC	ST5892BAA

2 Pin Assignment

NO.	PIN NAME	Description
1-2	A	Backlight LED Power
3-4	K	Backlight LED Ground
5	GND	Ground
6	VDD	A power supply for the logic power and I/O circuit.
7-14	R0-R7	Red data,R7 is MSB,R0 is LSB.
15-22	G0-G7	Green data,G7 is MSB,G0 is LSB.
23-30	B0-B7	Blue data,B7 is MSB,B0 is LSB.
31	GND	Ground
32	DCLK	Pixel clock input pin
33	STBYB	Standby mode
34	HSYNC	Horizontal sync signal; negative polarity
35	VSYNC	Vertical sync signal; negative polarity
36	DE	Data input enable. Active High to enable the data input
37	VPP	Power for OTP
38	SDA	Serial data input for SPI interface
39	SCL	Clock signal for SPI interface
40	CS	Chip select signal for SPI interface

3 Absolute Maximum Ratings

GND=0V, Ta= 25°C

Item	Symbol	Value	Unit
Power supply voltage for logic	V _{DD}	3.0~3.6	V
Input voltage	V _{in}	V _{DD} +0.3	V
Operating temperature	Topr	-20 to 70	°C
Storage temperature	Tstg	-30 to 80	°C

Note: Note1: Absolute maximum rating is the limit value beyond which the IC maybe broken.

They do not assure operations.

Note2: Background color changes slightly depending on ambient temperature. This Phenomenon is reversible.

4 Electrical Characteristics

4.1 Driving TFT LCD Panel

Item	Symbol	Min	Type	Max	Unit	Test condition
Power voltage	VDD	3.0	3.3	3.6	V	-
Input logic high voltage	V _{IH}	0.9VDD	-	VDD	V	
Input logic low voltage	V _{IL}	0	-	0.3VDD	V	

4.2 Driving Backlight

Ta=25°C

Item	Symbol	Min	Typ	Max	Unit	Remark
Forward Current	I _F	--	180	--	mA	
Forward Voltage	V _F	16.8	20.4	-	V	
Connection mode	-	--	6S2P	--		
LED number	/		12		pcs	
LED Life			20000		Hrs	

Note1: Optical performance should be evaluated at Ta=25°C only .If LED is driven by high current, high ambient temperature & humidity condition. The life time of LED will be reduced. Operating life means brightness goes down to 50% initial brightness. Typical operating life time is estimated data.

LED CIRCUIT DIAGRAM:

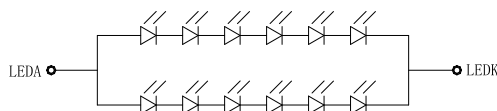

I_f=180mA V_f=16.8~20.4V

4.3 Block Diagram

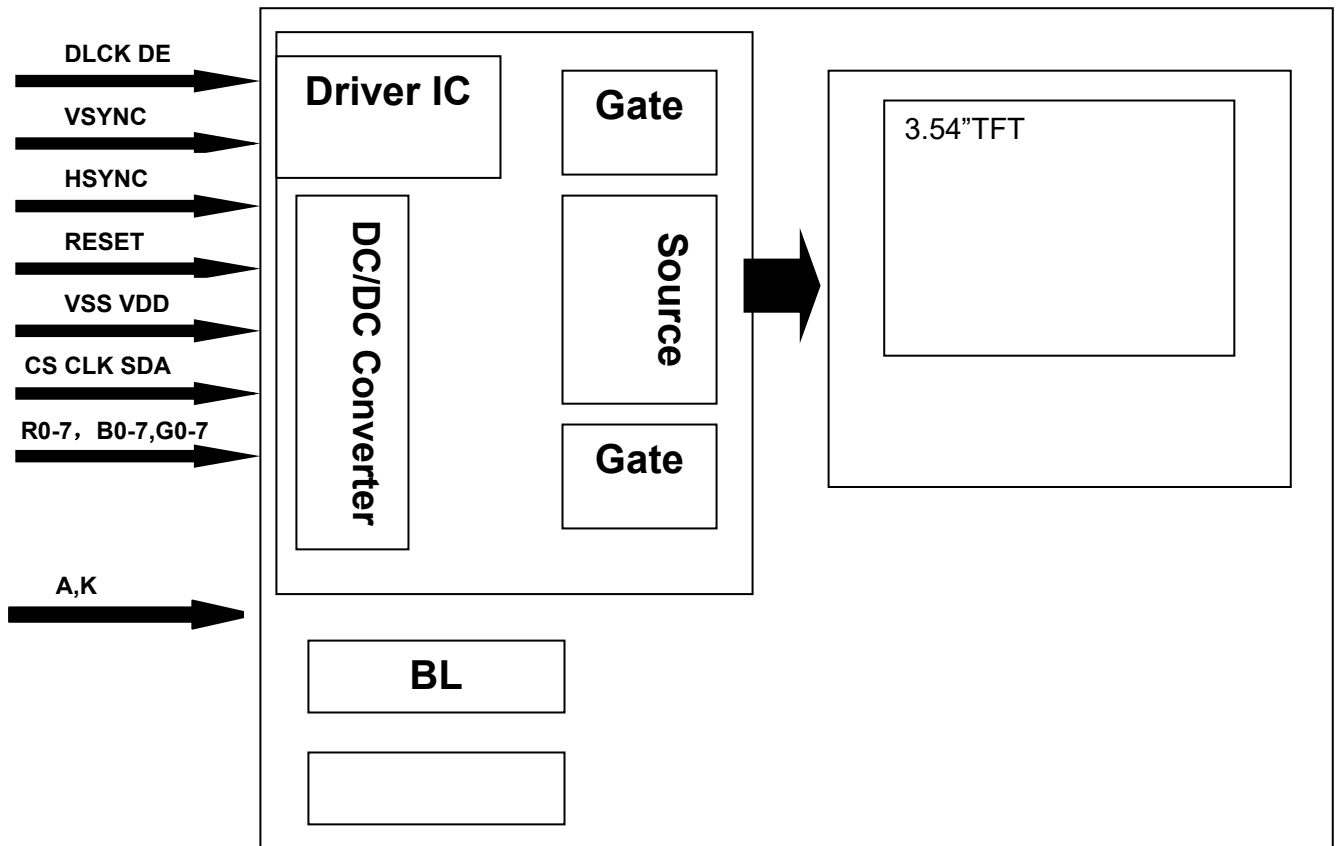

5 INTERFACE TIMING

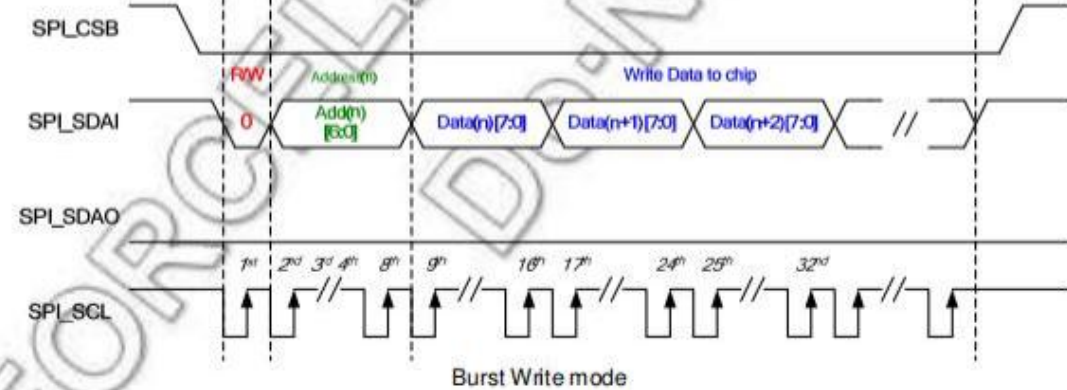
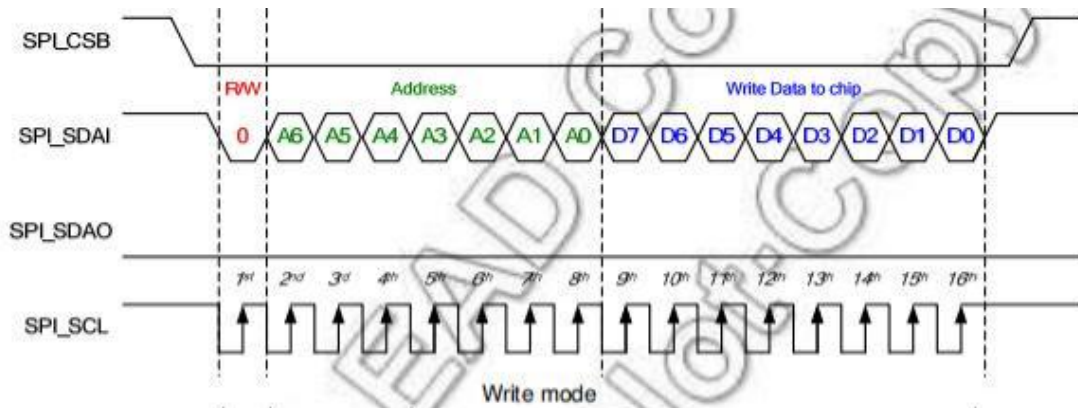
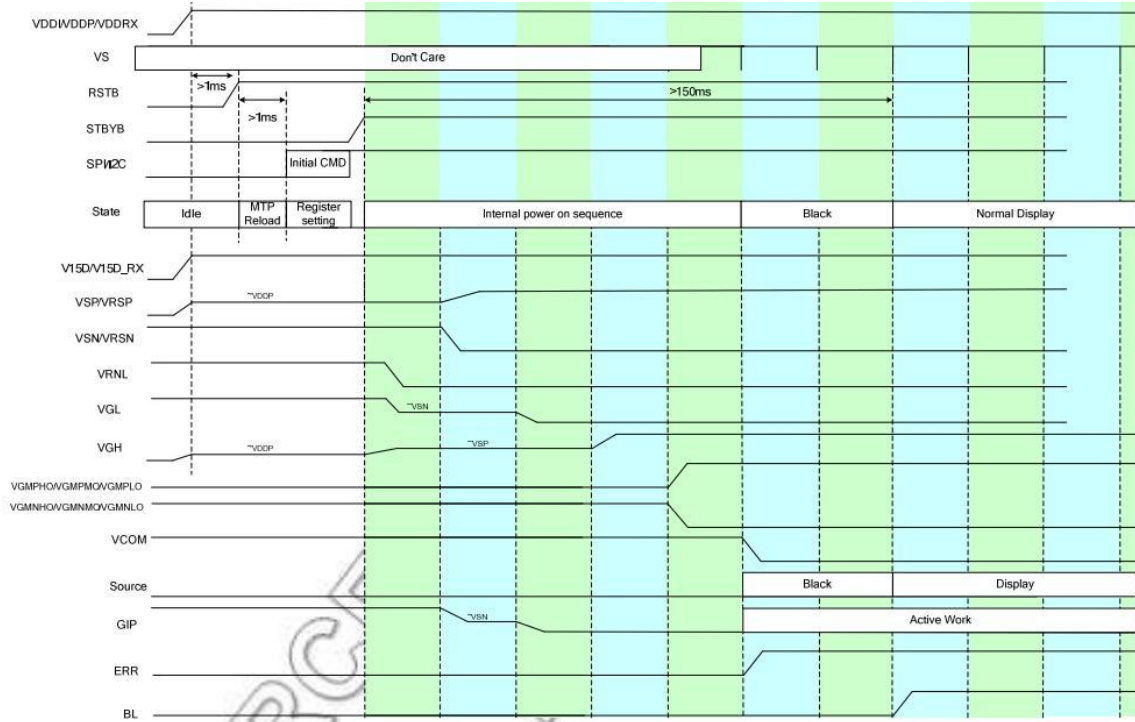

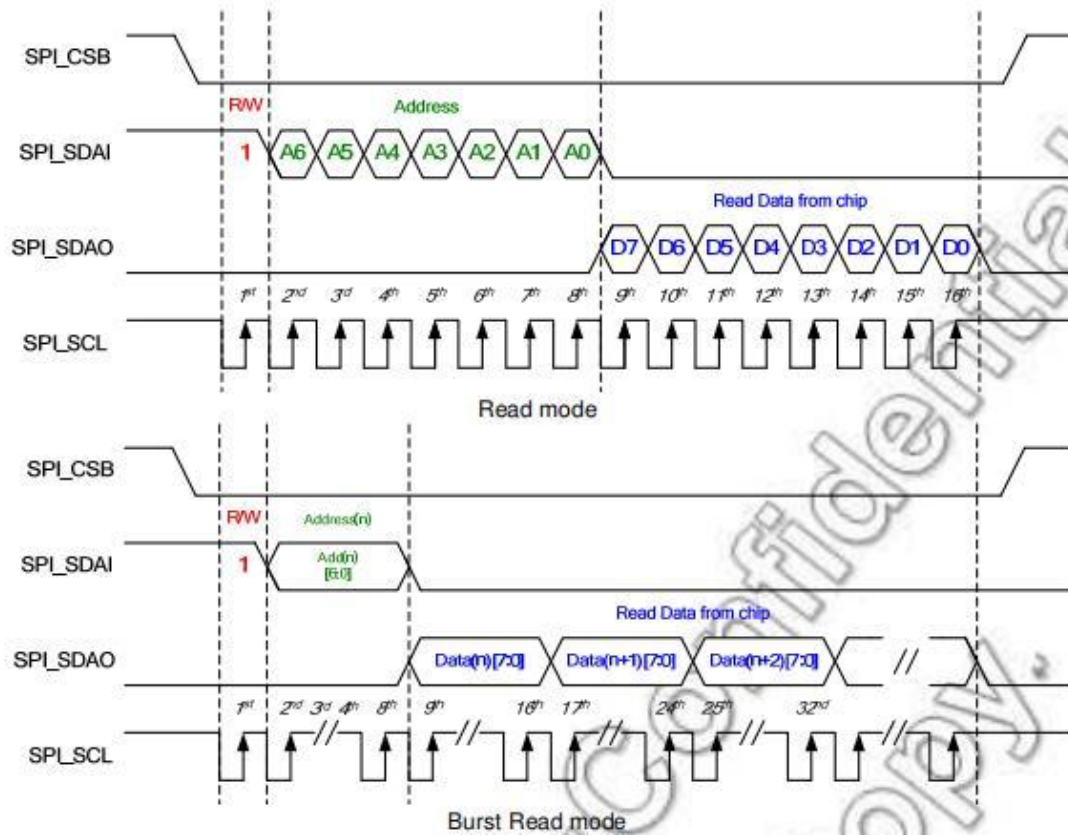

Parallel RGB888

Pin	1 st Data	2 nd Data	3 rd Data	...	N th Data
D00	1'R0	2'R0	3'R0	...	N'R0
D01	1'R1	2'R1	3'R1	...	N'R1
D02	1'R2	2'R2	3'R2	...	N'R2
D03	1'R3	2'R3	3'R3	...	N'R3
D04	1'R4	2'R4	3'R4	...	N'R4
D05	1'R5	2'R5	3'R5	...	N'R5
D06	1'R6	2'R6	3'R6	...	N'R6
D07	1'R7	2'R7	3'R7	...	N'R7
D10	1'G0	2'G0	3'G0	...	N'G0
D11	1'G1	2'G1	3'G1	...	N'G1
D12	1'G2	2'G2	3'G2	...	N'G2
D13	1'G3	2'G3	3'G3	...	N'G3
D14	1'G4	2'G4	3'G4	...	N'G4
D15	1'G5	2'G5	3'G5	...	N'G5
D16	1'G6	2'G6	3'G6	...	N'G6
D17	1'G7	2'G7	3'G7	...	N'G7
D20	1'B0	2'B0	3'B0	...	N'B0
D21	1'B1	2'B1	3'B1	...	N'B1
D22	1'B2	2'B2	3'B2	...	N'B2
D23	1'B3	2'B3	3'B3	...	N'B3
D24	1'B4	2'B4	3'B4	...	N'B4
D25	1'B5	2'B5	3'B5	...	N'B5
D26	1'B6	2'B6	3'B6	...	N'B6
D27	1'B7	2'B7	3'B7	...	N'B7

SYNC MODE

Parallel RGB

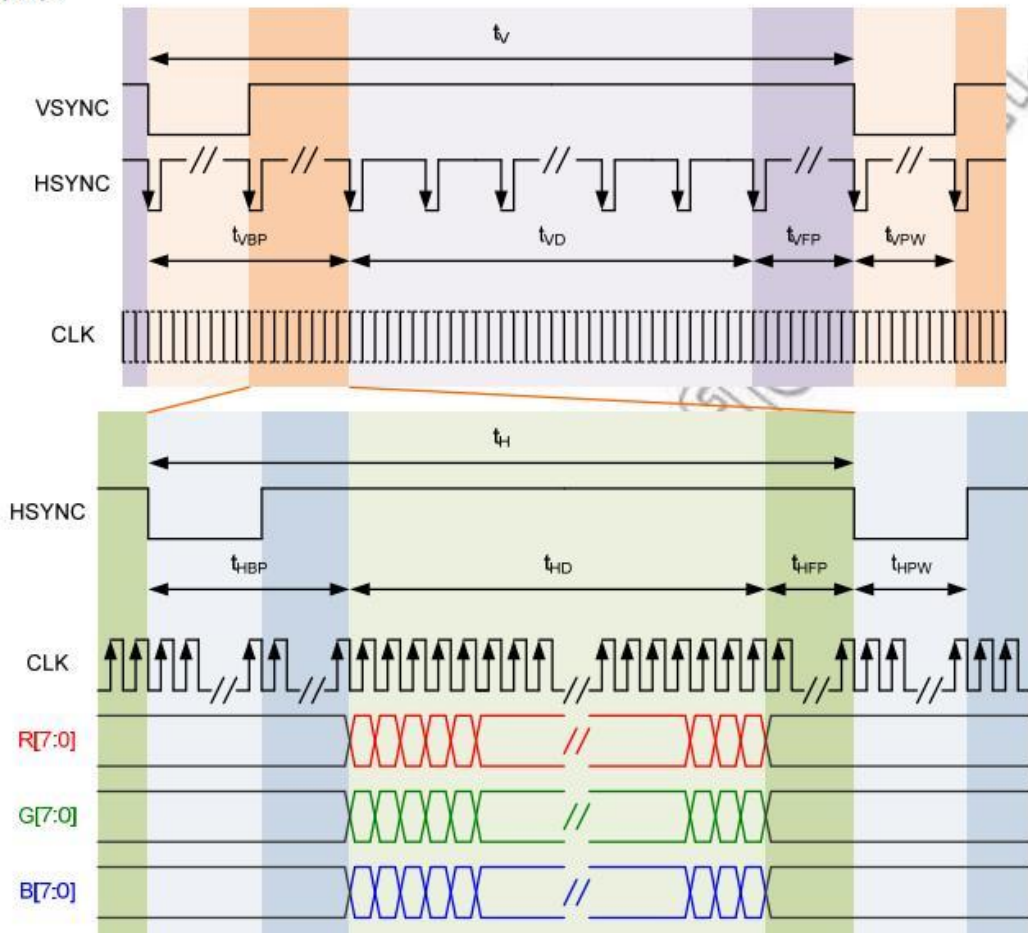



DE MODE

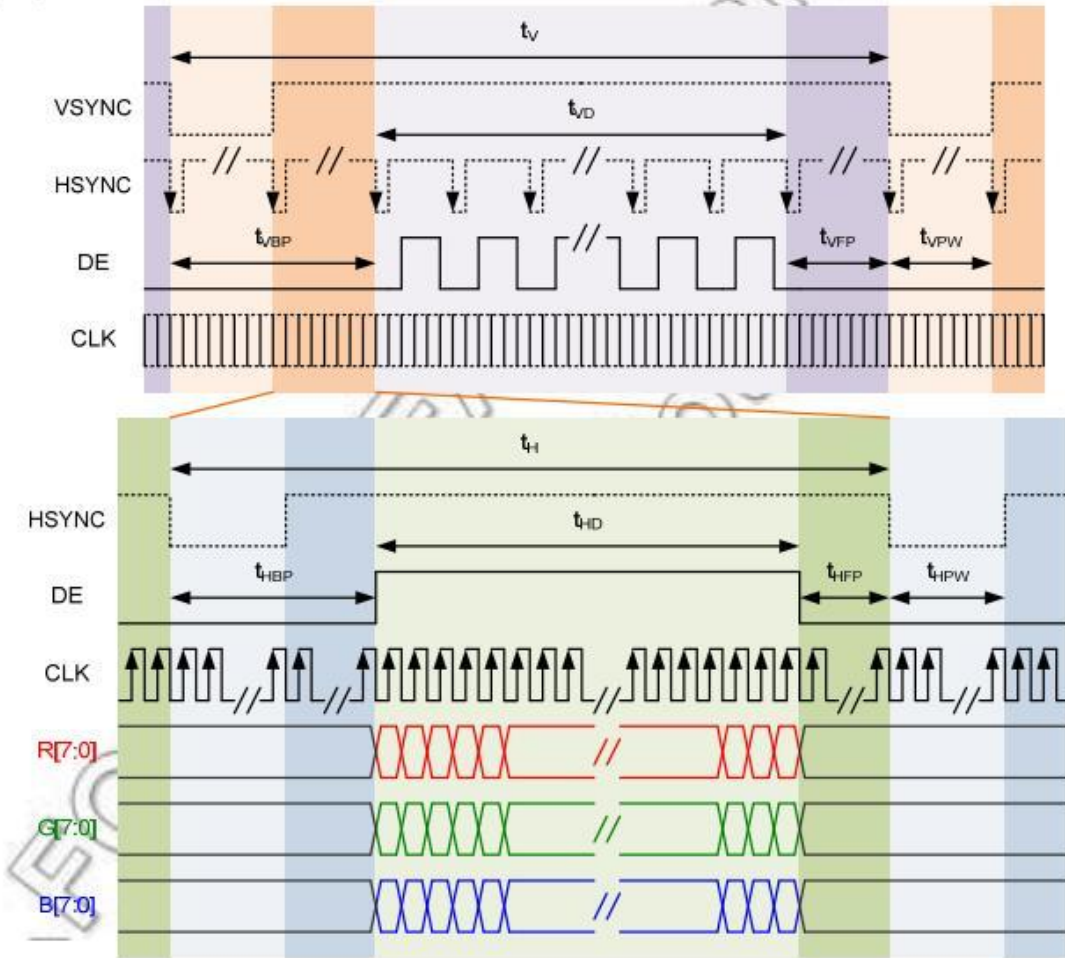

5.1 Power ON/OFF Timing

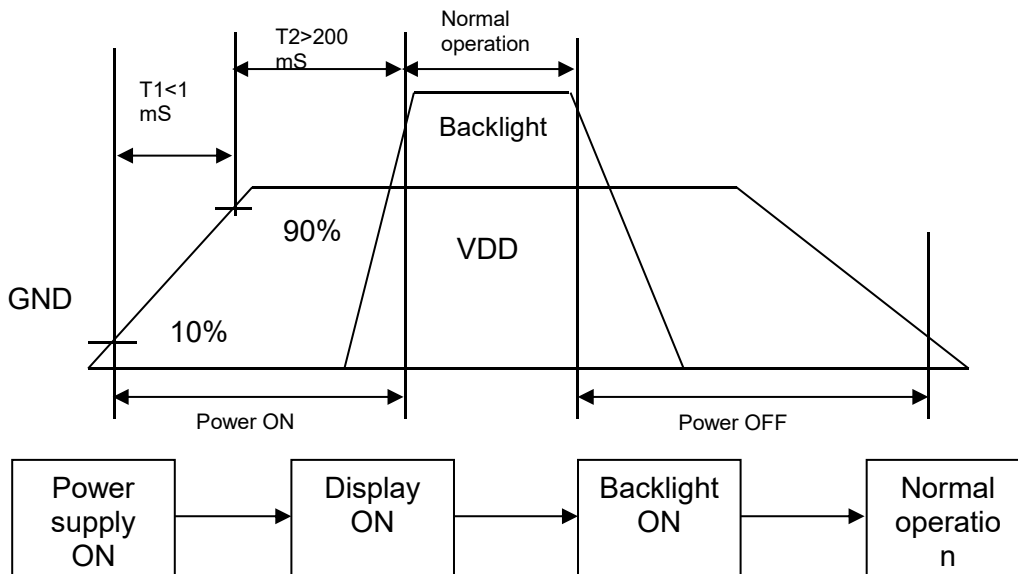

Power ON sequence

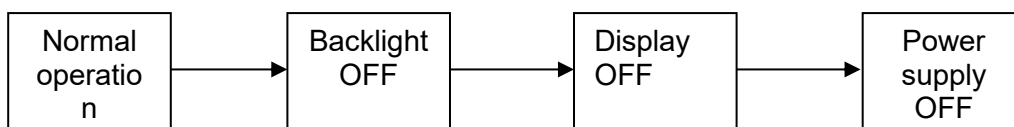

Power OFF sequence

6 Optical Characteristics

Ta=25°C

Item	Symbol	Condition	Min	Typ	Max	Unit	Remark
View Angles	θT	CR ≥ 10	80	85	-	Degree	Note 2
	θB		80	85	-		
	θL		80	85	-		
	θR		80	85	-		
Contrast Ratio	CR	θ=0°	1000	1200	-	-	Note1 Note3
Response Time	T _{ON}	25°C	-	30	40	ms	Note1 Note4
	T _{OFF}		-	30	40		
Uniformity	U	-	70	80	-	%	Note1 Note6
NTSC	-	-	65	70	-	%	Note 5
Luminance	L	-	1000	1200	-	cd/m ²	Note1 Note7

Test Conditions:

1. V_F=20.4V, I_F=180mA, the ambient temperature is 25°C.
2. The test systems refer to Note 1 and Note 2.

Note 1: Definition of optical measurement system.

The optical characteristics should be measured in dark room. After 5 minutes operation, the optical properties are measured at the center point of the LCD screen. All input terminals LCD panel must be ground when measuring the center area of the panel.

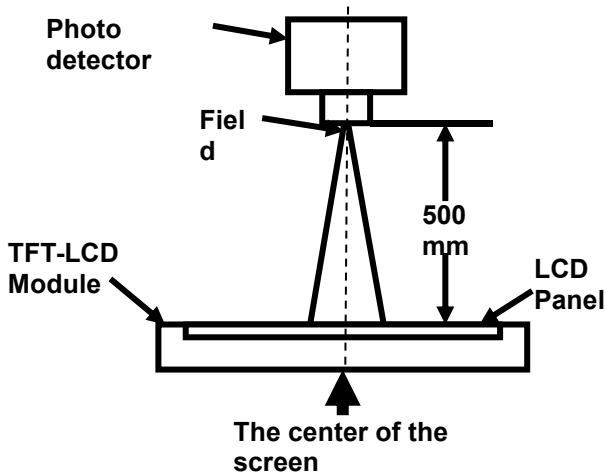

Item	Photo detector	Field
Contrast Ratio	SR-3A	1°
Luminance		
Chromaticity		
Lum Uniformity	BM-7A	2°
Response Time		

Note 2: Definition of viewing angle range and measurement system.

viewing angle is measured at the center point of the LCD by CONOSCOPE(ergo-80).

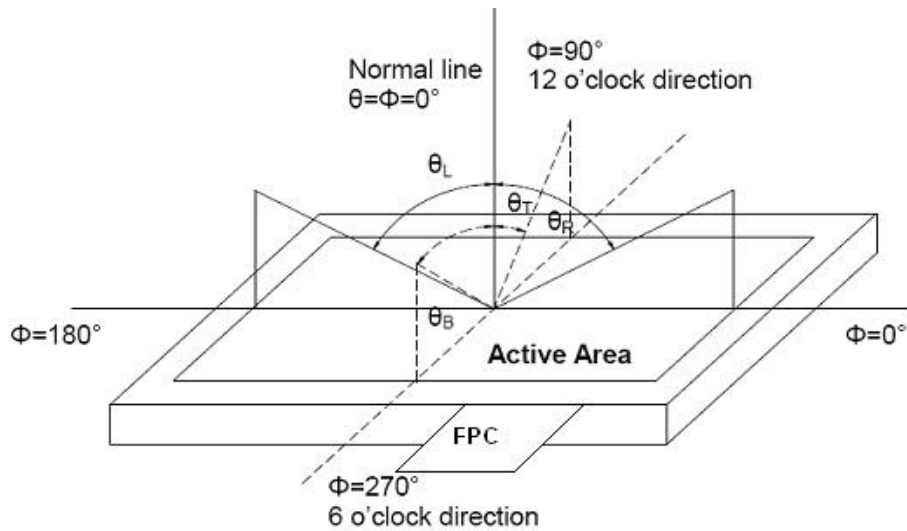

Fig. 1 Definition of viewing angle

Note 3: Definition of contrast ratio

$$\text{Contrast ratio (CR)} = \frac{\text{Luminance measured when LCD is on the "White" state}}{\text{Luminance measured when LCD is on the "Black" state}}$$

“White state”: The state is that the LCD should be driven by V_{white} .

“Black state”: The state is that the LCD should be driven by V_{black} .

V_{white} : To be determined V_{black} : To be determined.

Note 4: Definition of Response time

The response time is defined as the LCD optical switching time interval between “White” state and “Black” state. Rise time (T_{ON}) is the time between photo detector output intensity changed from 90% to 10%. And fall time (T_{OFF}) is the time between photo detector output intensity changed from 10% to 90%.

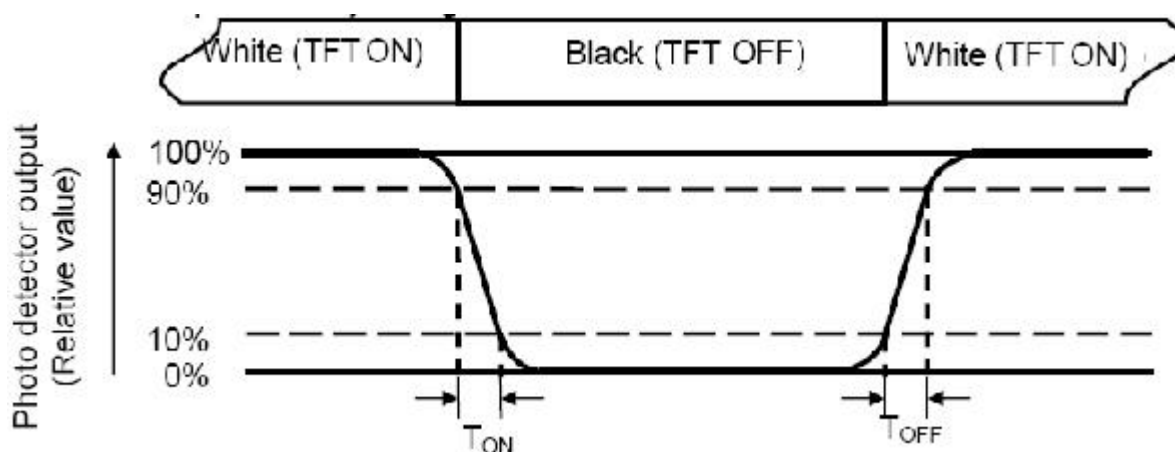

Note 5: Definition of color chromaticity (CIE1931)

Color coordinates measured at center point of LCD.

Note 6: Definition of Luminance Uniformity

Active area is divided into 9 measuring areas (Refer Fig. 2). Every measuring point is placed at the center of each measuring area.

Luminance Uniformity (U) = L_{min} / L_{max}

L-----Active area length W----- Active area width

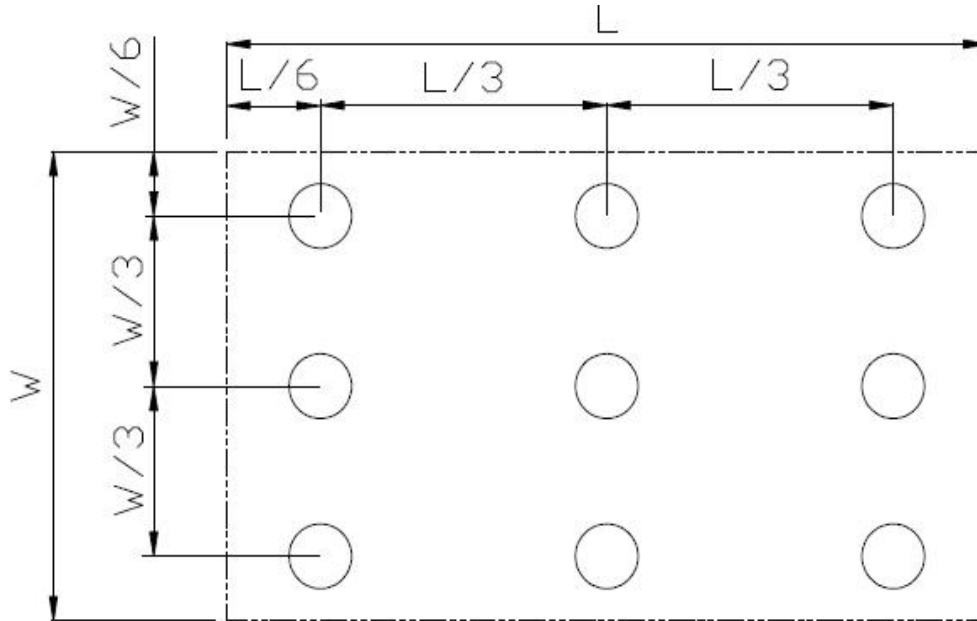

Fig. 2 Definition of uniformity

L_{max} : The measured maximum luminance of all measurement position.

L_{min} : The measured minimum luminance of all measurement position.

Note 7: Definition of Luminance:

Measure the luminance of white state at center point.

7 Environmental / Reliability Test

Item	Condition	Time (hrs)	Assessment
High temp. Storage	80°C	120	No abnormalities in functions and appearance
High temp. Operating	70°C	120	
Low temp. Storage	-30°C	120	
Low temp. Operating	-20°C	120	
Humidity	60°C/ 90%RH	120	
Thermal Shock(Non-operation)	-0°C ← 25°C →70°C (0.5 hour ← 5 min → 0.5 hour)	10cycles	

Remark:

- 1.The test samples should be applied to only one test item.
- 2.Sample size for each test item is 1~10pcs.
- 3.In case of malfunction defect caused by ESD damage, if it would be recovered to normal state after resetting, it would be judged as a good part.

8 Mechanical Drawing

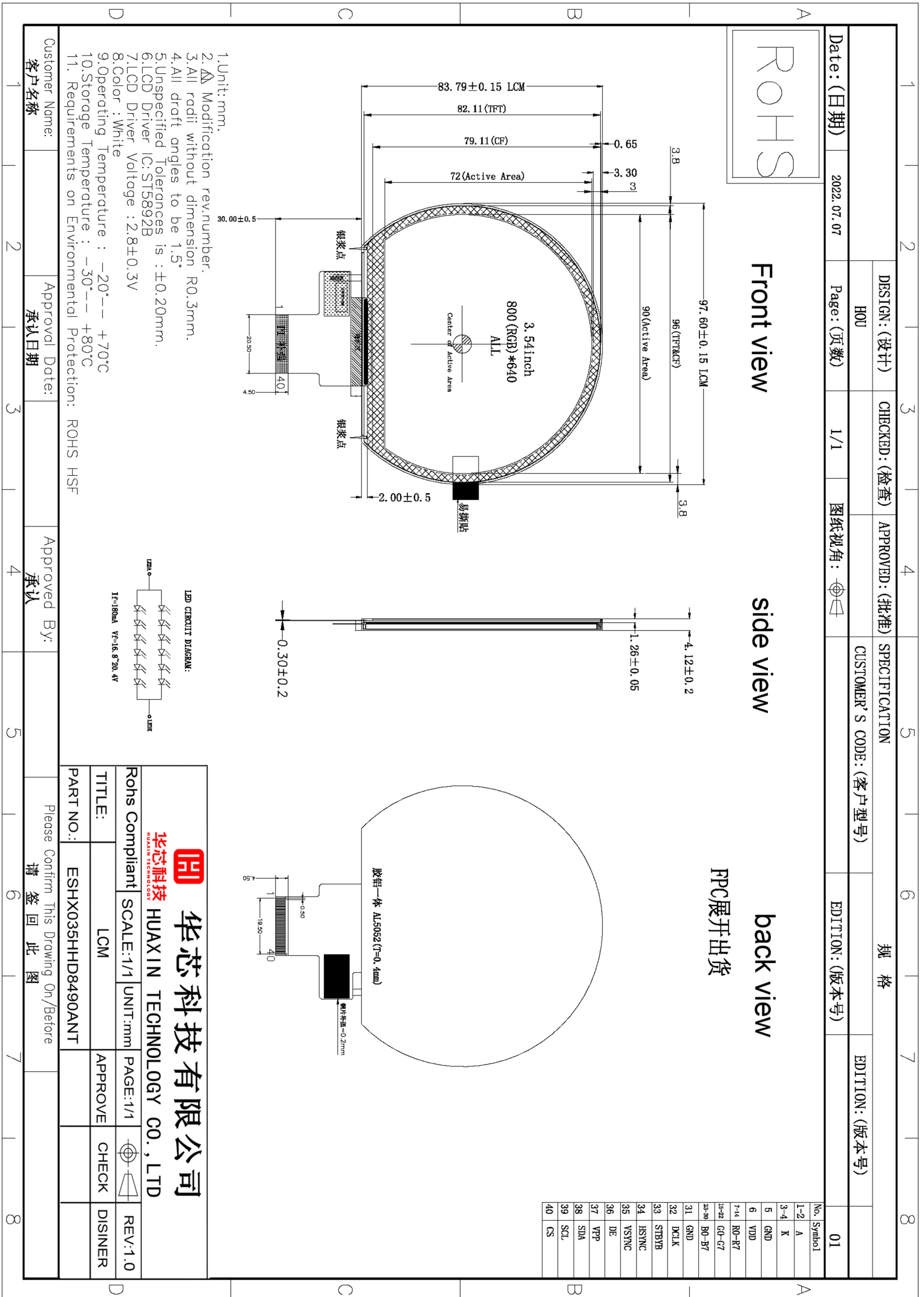

9 Precautions For Use of LCD Modules

9.1 Handling Precautions

9.1.1.1 The display panel is made of glass. Do not subject it to a mechanical shock by dropping it from a high place, etc.

9.1.1.2 If the display panel is damaged and the liquid crystal substance inside it leaks out, be sure not to get any in your mouth, if the substance comes into contact with your skin or clothes, promptly wash it off using soap and water.

9.1.1.3 Do not apply excessive force to the display surface or the adjoining areas since this may cause the color tone to vary.

9.1.1.4 The polarizer covering the display surface of the LCD module is soft and easily scratched. Handle this polarizer carefully.

9.1.1.5 If the display surface is contaminated, breathe on the surface and gently wipe it with a soft dry cloth. If still not completely clear, moisten cloth with one of the following solvents:

- Isopropyl alcohol
- Ethyl alcohol

Solvents other than those mentioned above may damage the polarizer. Especially, do not use the following:

- Water
- Ketone
- Aromatic solvents

9.1.1.6 Do not attempt to disassemble the LCD Module.

9.1.1.7 If the logic circuit power is off, do not apply the input signals.

9.1.1.8 To prevent destruction of the elements by static electricity, be careful to maintain an optimum work environment.

9.1.1.9 Be sure to ground the body when handling the LCD Modules.

9.1.1.10 Tools required for assembly, such as soldering irons, must be properly ground.

9.1.1.11 To reduce the amount of static electricity generated, do not conduct assembly and other work under dry conditions.

9.1.1.12 The LCD Module is coated with a film to protect the display surface. Be care when peeling off this protective film since static electricity may be generated.

9.1.1.13 Storage precautions

9.1.1.14 When storing the LCD modules, avoid exposure to direct sunlight or to the light of fluorescent lamps.

9.1.1.15 The LCD modules should be stored under the storage temperature range. If the LCD modules will be stored for a long time, the recommend condition is:

9.1.1.16 The LCD modules should be stored in the room without acid, alkali and harmful gas.

9.2 Transportation Precautions

The LCD modules should be no falling and violent shocking during transportation, and also should avoid excessive press, water, damp and sunshine.
